

# Ventionex

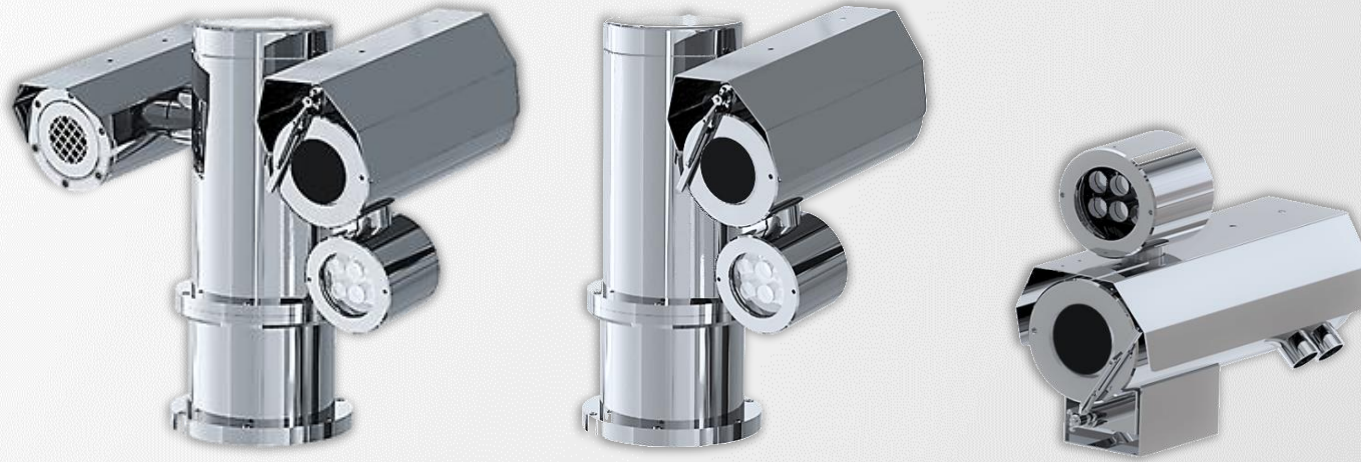

CCTV

Solutions

Always Customer Centric,  
To Serve & Contribute,  
with Latest Useful  
Technologies





Ventionex

About

Us



## BACKGROUND

Established since year 2009, with more than 10 years of experience and core strength in software integration and systems implementation, our turnkey solution offerings cover a wide range of business area from onshore township security to critical offshore Oil & Gas command & control.

The solutions that we offer shall be scalable and ease of upgrading, in order to meet the ever-increasing security and command & control challenges every day.

## VISION & MISSION

To be the best in offering latest useful security and command & control solutions to critical infrastructure and governments.

To empathize, inform and fulfil the need of trustworthy useful security and command & control solutions of our clients, to enable high efficiency in operations that can save lives and resources, and make better decisions for good.

## QUALITY POLICY

To develop long term mutual beneficial and profitable relationship with Clients, through meeting Clients' requirement, while seeking to improve our products, solutions and services with latest technology and innovative business practices.

## CONTINUOUS ADVANCEMENT

Ventionex is the member of Public Private Research Network (PPRN) initiated by Ministry of Education Malaysia. We are in collaboration with University Kebangsaan Malaysia (UKM), University Technology Malaysia (UTM), Malaysia Technology Development Corporation (MTDC) and Malaysia Petroleum Resources Corporation (MPRC) for continuous joint technology development and commercialization of other research and development products of the universities.

## COMPLETE CCTV SOLUTIONS

Ventionex has the experience and capability in offering turnkey consultancy, survey, design, manufacturing, engineering and commissioning of complete CCTV solutions, range from onshore township surveillance to critical offshore Oil & Gas operation. The solutions that we offer shall be scalable and ease of upgrading, in order to meet the increasing security and surveillance challenge every day.

The following diagram illustrates our complete CCTV solutions offering :

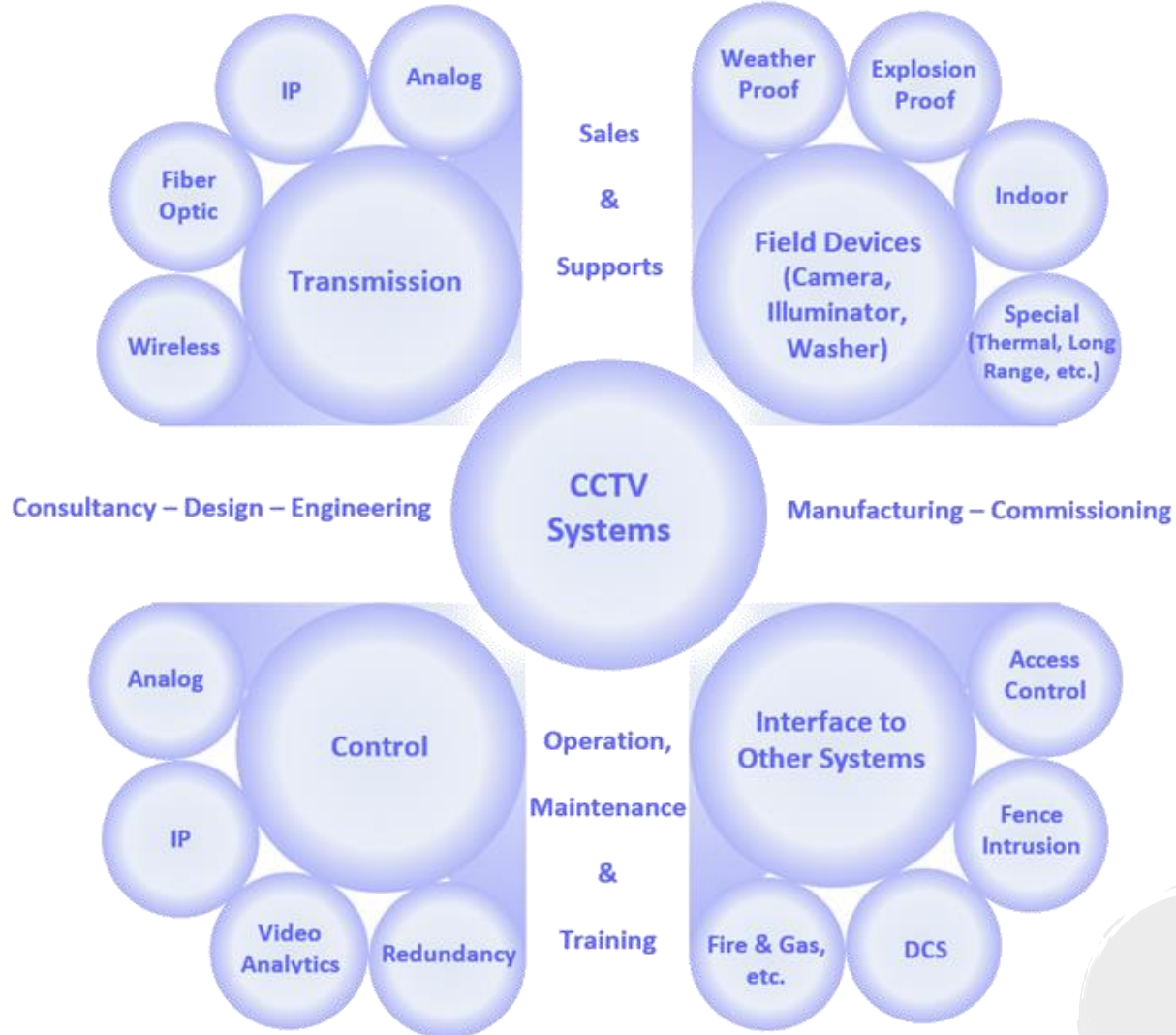

We have a strong technical and sales team with in depth knowledge and experience, of which shall meet the expectation of the customers, from sales support, technical support, training, to operation and maintenance.

## ADVANCED & HAZARDOUS AREA CERTIFIED SECURITY PRODUCTS

We research and develop our own products that meet the requirement of industrial and hazardous area, with products certified to explosion proof ATEX Standards EN 60079-0: 2018, EN 60079-1: 2014, EN 60079-28: 2015 and EN 60079-31: 2014; IECEx Standards IEC 60079-0: 2017, IEC 60079-1: 2014, IEC 60079-28: 2015 and IEC 60079-31: 2013; INMETRO's Ordinance n°. 115. For more products information, please visit our website : [www.ventionex.com](http://www.ventionex.com)



### SX1PTZD Series

- Ex II 2 G Ex db op pr IIC T6 Gb
- Ex II 2 D Ex tb op pr IIIC T80°C Db
- Explosion Proof Pan & Tilt Dual Camera Station series with options for thermal camera, wiper and LED Illuminator.



### SX1PTZ Series

- Ex II 2 G Ex db op pr IIC T6 Gb
- Ex II 2 D Ex tb op pr IIIC T80°C Db
- Explosion Proof Pan & Tilt Camera Station series with options for thermal camera, wiper and LED Illuminator.



### SX1 Series

- Ex II 2 G Ex db op pr IIC T6 Gb
- Ex II 2 D Ex tb op pr IIIC T80°C Db
- Explosion Proof Fixed Camera Station with options for thermal camera, wiper and LED Illuminator.



### PWX1 Series

- Ex II 2 G Ex d IIC T6 Gb
- Ex II 2 D Ex tb IIIC T80°C Db
- Explosion Proof CCTV Washer System



## INTELLIGENT VIDEO ANALYTICS

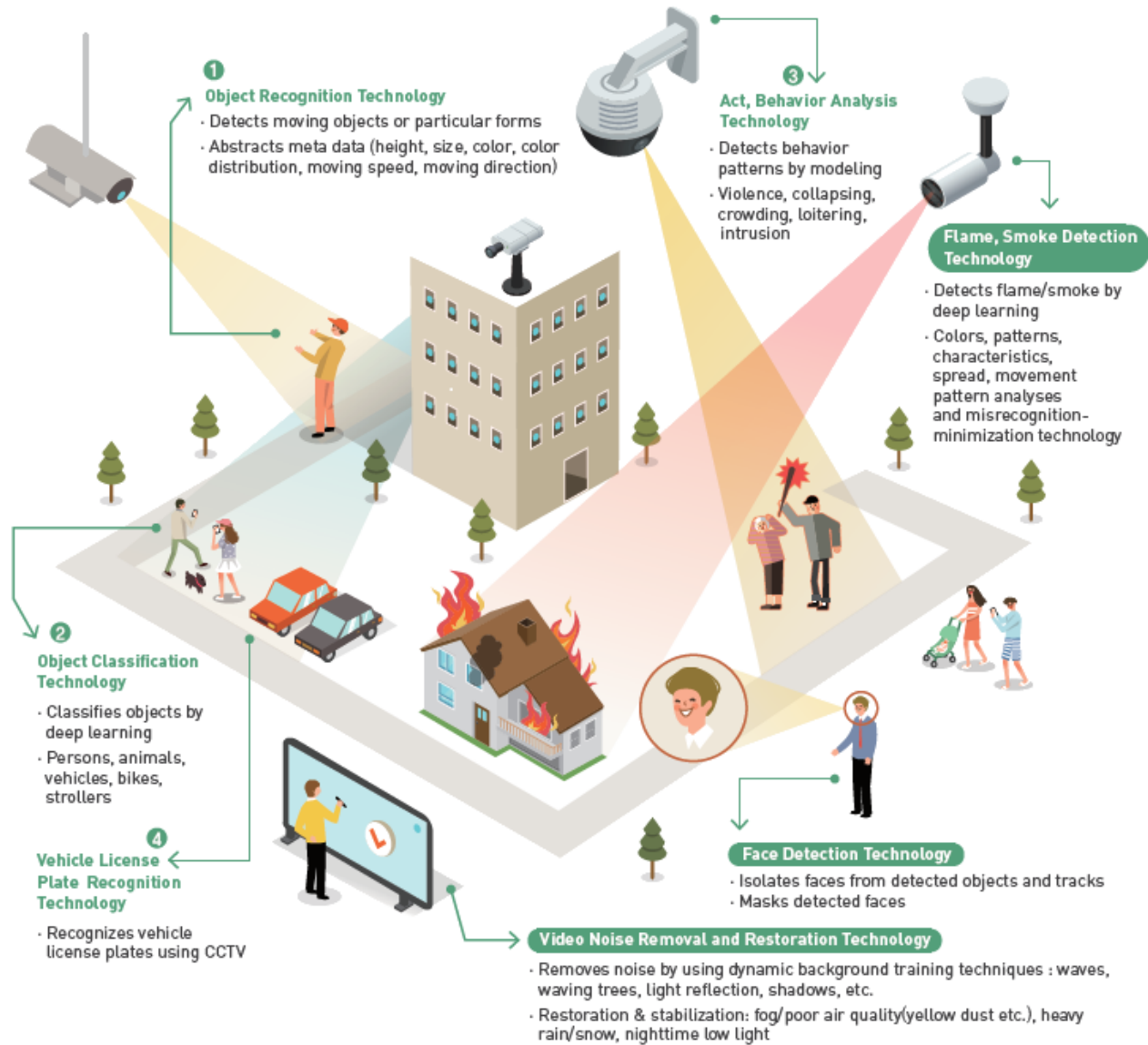



## ACCREDITATIONS



- ATEX Quality Assurance Notification, Equipment or Protective Systems or Components intended for use in Potentially Explosive Atmospheres Directive 2014/34/EU
- ATEX EU Type Examination Compliance Standards EN 60079-0: 2018, EN 60079-1: 2014, EN 60079-28: 2015 and EN 60079-31: 2014
- IECEX Quality Assessment Report, compliance of ISO 9001 and ISO/IEC 80079-34
- IECEX Certificate of Conformity Compliance Standards IEC 60079-0: 2017, IEC 60079-1: 2014, IEC 60079-28: 2015 and IEC 60079-31: 2013
- INMETRO's Ordinance n°. 115



- Quality Management System - ISO 9001: 2015

## Our Certificates



### Certificate of Registration

**QUALITY MANAGEMENT SYSTEM**

This is to certify that: **Ventionex International Sdn Bhd**  
No 2, Jalan Laman Setia 7/6  
Setia Business Park,  
Gelang Patah, Johor  
81550  
Malaysia

Is included as a location on Certificate number: **FS 680595**  
This is a multiple-site certificate and this BSI location is: 0047656063-002  
and operates a Quality Management System which complies with the requirements of ISO 9001:2015 for the following scope:  
**The project management of the design, manufacture, assembly, testing and commissioning, supplies and servicing of closed circuit television (CCTV), communications, security and safety systems**

For and on behalf of BSI:  
  
**Chris Cheung, Head of Compliance & Risk - Asia Pacific**

Original Registration Date: 2012-09-27      Effective Date: 2020-11-22  
Latest Issue: 2020-10-02                      Expiry Date: 2023-11-21





...making excellence a habit™

This certificate is not the legal certificate and is for presentation purposes only. Refer to the legal certificate for full details of conditions and scope. This certificate remains the property of BSI and is bound by the conditions of the contract.

Information and Contact: BSI, Market Court, Davy Avenue, Kilmarnock, Midlothian EH3 8PP, UK. Tel: +44 346 080 9000  
BSI Americas UK Limited, registered in England under number 7893322 at 389 Chiswick High Road, London W6 4AL, UK.  
A Member of the BSI Group of Companies.



### Certificate of Registration

**QUALITY MANAGEMENT SYSTEM - ISO 9001:2015**

This is to certify that: **Ventionex International Pte Ltd**  
10 Bukit Batok Crescent  
#05-05 The Square,  
Singapore 658079

Holds Certificate No: **FS 680595**  
and operates a Quality Management System which complies with the requirements of ISO 9001:2015 for the following scope:  
**The project management of the design, manufacture, assembly, testing and commissioning, supplies and servicing of closed circuit television (CCTV), communications, security and safety systems**

For and on behalf of BSI:  
  
**Nadege Claudel, General Manager**

Original Registration Date: 2012-09-27      Effective Date: 2020-11-22  
Latest Revision Date: 2020-10-02              Expiry Date: 2023-11-21

Pages: 1 of 2





...making excellence a habit™

This certificate was issued electronically and remains the property of BSI and is bound by the conditions of the contract. An electronic certificate can be authenticated online. Printed copies can be validated at www.bsigroup.com/Certificate or telephone +44 346 270277. Further clarifications regarding the scope of this certificate and the applicability of ISO 9001:2015 requirements may be obtained by consulting the organisation. This certificate is valid only if printed original copies are in complete set.

BSI Group Singapore Pte Ltd: 77 Robinson Road, #20-01, Robinson 77, Singapore 068966  
A Member of the BSI Group of Companies.



### Certificate of Registration

**QUALITY MANAGEMENT SYSTEM**

This is to certify that: **Ventionex Innovations Sdn Bhd**  
No 2, Jalan Laman Setia 7/6  
Setia Business Park,  
Gelang Patah, Johor  
81550  
Malaysia

Is included as a location on Certificate number: **FS 680595**  
This is a multiple-site certificate and this BSI location is: 0047656063-003  
and operates a Quality Management System which complies with the requirements of ISO 9001:2015 for the following scope:  
**The project management of the design, manufacture, assembly, testing and commissioning, supplies and servicing of closed circuit television (CCTV), communications, security and safety systems**

For and on behalf of BSI:  
  
**Chris Cheung, Head of Compliance & Risk - Asia Pacific**

Original Registration Date: 2012-09-27      Effective Date: 2020-11-22  
Latest Issue: 2020-10-02                      Expiry Date: 2023-11-21





...making excellence a habit™

This certificate is not the legal certificate and is for presentation purposes only. Refer to the legal certificate for full details of conditions and scope. This certificate remains the property of BSI and is bound by the conditions of the contract.

Information and Contact: BSI, Market Court, Davy Avenue, Kilmarnock, Midlothian EH3 8PP, UK. Tel: +44 346 080 9000  
BSI Americas UK Limited, registered in England under number 7893322 at 389 Chiswick High Road, London W6 4AL, UK.  
A Member of the BSI Group of Companies.

### Certificado de Conformidade Ex

Ex: Certificate of Conformity

Modelo com Avaliação do Sistema de Gestão da Qualidade do Processo de Produção e Ensaios no Produto (5)

Model with Assessment of Quality Management System of Production Process and Test on Product (5)

Certificado Nº: Certificate Nº:	NCC 22.0057 X	Revisão/Issue nº: 0
Data de emissão/Issue Date:	14/05/2022	Certificado de Conformidade válido somente acompanhado das páginas 1 a 5 (Certificado valid only when accompanied of pages 1 through 5)
Data de validade/Validity Date:	14/05/2028	
Solicitante/Client:	VENTIONEX INNOVATIONS SDN BHD	
Fabricante/Manufacturer:	No.2, Jalan Laman Setia 7/6, Setia Business Park, Gelang Patah, Johor, 81550, Malaysia	
Produto/Product:	Câmeras, Série SX1	
Marca Comercial/Trade Name:	N/A	
Tipo principal de proteção/Main type of protection:	II, op. 1	
Marcação/Marking:	Ex db op pr IIC T8 Gb Ex tb op pr IIIC T80°C Db (-40°C ≤ T <sub>amb</sub> ≤ +60°C)	
Aprovado para emissão em conformidade com o regulamento e normas aplicáveis/Approved for issue in conformity with rule and applicable standards:		ISAIAS TEIXEIRA DO CARMO JUNIOR Gerente de Processo
Posição/Position:		ISAIAS TEIXEIRA DO CARMO JUNIOR Gerente de Processo

Certificado emitido conforme requisitos da avaliação do conformidade de equipamentos elétricos para atmosferas explosivas, anexo ao Portaria Imetro nº 115 de 21 de março de 2022.

Certificate issued in accordance to Brazilian requirements attached to IMMETRO's Ordinance nº. 115 issued on March 21st, 2022.

- Este certificado somente pode ser reproduzido com todas as folhas. This certificate may only be reproduced in full.
- Este certificado não é transferível e é de propriedade do organismo emissor. This certificate is not transferable and remains the property of the issuing body.
- A situação e a autoridade deste certificado podem ser verificadas no website oficial do Imetro. The status and authority of this certificate may be verified by visiting the website of the Imetro.
- Este certificado de conformidade foi emitido por um organismo de verificação acreditado pela CG-1 - Coordenação Geral de Acreditação. This certificate of conformity was issued by a certification body accredited by CG-1.

Certificado emitido por:  
certificate issued by:

NCC Certificações do Brasil Ltda  
Acreditação Signat nº 0314 (04/03/2021)  
Av. Osimário Maia, nº 365, Campinas, SP, Brasil, CEP 13010-211  
CNPJ nº 16.537.16/0001-26  
www.ncc.com.br



NCC 205      Page 1 of 5      Rev. 27



### IECEx Certificate of Conformity

**INTERNATIONAL ELECTROTECHNICAL COMMISSION  
IEC Certification System for Explosive Atmospheres**  
for rules and details of the IECEx Scheme visit www.iecex.com



Certificate No.:	IECEx CML 19/0160X	Page 1 of 4	Certificate History: Issue 0 (2020/04/24)
Status:	Current	Issue No: 1	
Date of Issue:	2020/11/11		
Applicant:	Ventionex Innovations Sdn Bhd No.2, Jalan Laman Setia 7/6, Setia Business Park, Gelang Patah, Johor 81550 Malaysia		
Equipment:	SX1 Series Cameras		
Optional accessory:			
Type of Protection:	Flameproof "d", Optical Radiation "op pr", Dust Ignition "td"		
Marking:	Ex db op pr IIC T8 Gb Ex tb op pr IIIC T80°C Db T <sub>amb</sub> -40°C to +60°C		

Approved for issue on behalf of the IECEx Certification Body: **S. Roubbedakis**  
Position: **Technical Manager**  
Signature:   
(for printed version)  
Date: 2020-11-11

1. This certificate and annex may only be reproduced in full.  
2. This certificate is not transferable and remains the property of the issuing body.  
3. The status and authority of this certificate may be verified by visiting www.iecex.com or via the QR Code.

Certificate issued by:  
Eurofins EAE CML Limited  
Unit 1, Newport Business Park  
Newport Road,  
Billemere Port, CH65 4LZ  
United Kingdom





**certification management**



### EU Type Examination Certificate CML 19ATEX1451X Issue 1

- Equipment intended for use in Potentially Explosive Atmospheres Directive 2014/34/EU
- Equipment: **SX1 Series Cameras**
- Manufacturer: **Ventionex Innovations SDN BHD**
- Address: **No.2, Jalan Laman Setia 7/6, Setia Business Park, 81550, Gelang Patah, Johor, Malaysia**
- The equipment is specified in the description of this certificate and the documents to which it refers.
- CML B.V., Chamber of Commerce No 8738871, Koopvaardijweg 32, 490ACV Oosterhout The Netherlands, Notified Body Number 2776, in accordance with Article 17 of Directive 2014/34/EU of the European Parliament and of the Council, dated 26 February 2014, certifies that this equipment has been found to comply with the Essential Health and Safety Requirements relating to the design and construction of equipment intended for use in potentially explosive atmospheres given in Annex I to the Directive.
- The examination and test results are recorded in the confidential reports listed in Section 12. If an "X" suffix appears after the certificate number, it indicates that the equipment is subject to conditions of safe use (affecting correct installation or safe use). These are specified in Section 14.
- This EU Type Examination certificate relates only to the design and construction of the specified equipment or component. Further requirements of Directive 2014/34/EU Article 13 apply to the manufacture of the equipment or component and are separately certified.
- Compliance with the Essential Health and Safety Requirements, with the exception of those listed in the confidential report, has been demonstrated through compliance with the following documents:  
EN IEC 60070-0:2018      EN 60079-1:2014      EN 60070-28:2015  
EN 60070-31:2014
- The equipment shall be marked with the following:  
II 2 G D  
Ex db op pr IIC T8 Gb  
Ex tb op pr IIIC T80°C Db  
T<sub>amb</sub> -40°C to +60°C

This certificate shall only be copied in its entirety and without change

1 of 4

**S. Roubbedakis**  
Technical Manager

Date of issue: 09/05/2018



## CERTIFICATE

The Workplace Safety and Health Council  
is pleased to certify that

**VENTIONEX INTERNATIONAL PTE. LTD.**

has fulfilled the requirements to attain bizSAFE Level 3

This certificate will expire on 08/05/2021

  
**Winston Yew**  
Deputy Director, Industry Capability Building  
Workplace Safety and Health Council



Certificate No. E21530



## RECOGNIZED &amp; SUPPORTED BY THE GOVERNMENT



- Ventionex received the recognition and full support from Malaysia government, through the awarding of Oil & Gas Services & Equipment Development Grant (OGSE DG) from Malaysia Petroleum Resources Corporation (MPRC) in early year 2022.
- The grant is to support Ventionex in the development of their new product lines, SX1D & SX2BE Explosion Proof and Weather Proof Certified CCTV and IoT Related Products.

A large-scale industrial facility, likely a refinery or chemical plant, is shown at night. The scene is filled with complex piping, distillation columns, and storage tanks, all illuminated by warm yellow lights. In the foreground, several large, white, cylindrical storage tanks are prominent. The background shows a dark sky with some clouds and distant mountains.

PROJECT

References



## MAJOR CRITICAL INFRASTRUCTURE PROJECTS



Singapore LNG Corporation, Singapore



Ratu Songkhla FSO, Sabah International Petroleum



Pengerang Independent Terminal, Vopak PTSB



Oiltanking Oil Terminal, Singapore



Lotte Chemical Titan Petrochemical, Malaysia



Terminal Oceanic of Barra do Dande, Angola



Lion Chemical Refinery Complex, Afton, Singapore



Ikdam FPSO, Bertam oil field in PM307, off Peninsular Malaysia



TNB Manjung 4 Coal-Fired Power Plant, Malaysia



## MAJOR CRITICAL INFRASTRUCTURE PROJECTS (cont.)



Banyan Combined Cycle Power Plant 3 (CCP3), SembCorp, Singapore



Lamson FPSO, Vietnam



Domo De San Pedro Geothermal Power Plant, Mexico



Hải Vân Tunnel, Vietnam



Nghi Sơn Refinery & Petrochemical Complex, Vietnam



Campos Basin UOTE FSO, Brazil



Tuas Power Station Combined Cycle Power Plant 5 (CCP5), Singapore



Vopak Terminals, Singapore



TuasOne Waste-to-Energy Plant, Singapore



## OUR FOOTPRINTS

Overview of our successful projects across the globe.

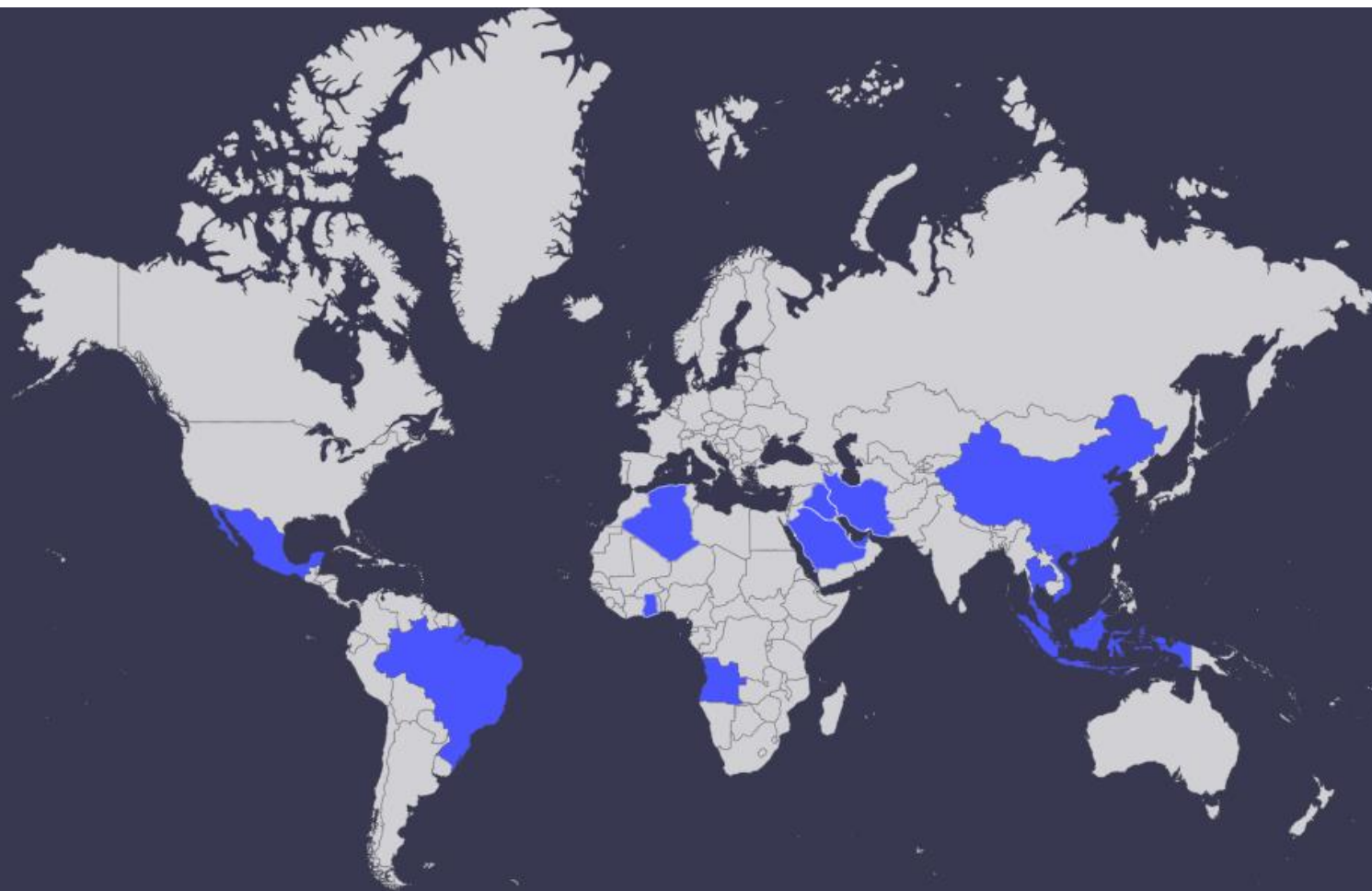

For more info about our projects and experience, please contact us at [enquiry@ventionex.com](mailto:enquiry@ventionex.com)

## THANK YOU

Feel free to contact us to learn more about our products and solution offering.  
We will be glad to assist you.

### Give us a call

- **Malaysia**  
+607 5950 387
- **Singapore**  
+65 6680 9321
- **Vietnam**  
+84 286 2727 704

### Email us at

[enquiry@ventionex.com](mailto:enquiry@ventionex.com)

### Our Website

<https://www.ventionex.com>

